

# iTP新型伺服节能二板式注塑机

iTP TWO-PLATEN SERVO ENERGY SAVING INJECTION MACHINE



**DEMARK**

# NEW SERVO HYDRAUIC ENERGY SAVING TWO-PLATEN INJECTION MACHINE

## 新型伺服节能两板式注塑机

- ▲ 德玛克新型两板机为市场提供了更高的选择标准，广泛应用的伺服驱动技术，以及优秀的机器设计，带来了德玛克新型两板注塑机高效节能的优势。
- ▲ 该新型两板机特别适合应用于汽车行业，白色家电行业，以及其他工业塑料产品。
- ▲ With widely used servo driving technology and excellent machine design, Denmark's new two-platen machine gains the advantage of energy saving, and becomes a higher selection standard for the market.
- ▲ The new two-platen machine is particularly suitable for automotive products, white home appliances, and other industrial plastic products.

白色家电

WHITE GOODS



汽车部件

AUTOMOTIVE



其它工业产品

INDUSTRIAL PLASTIC GOODS

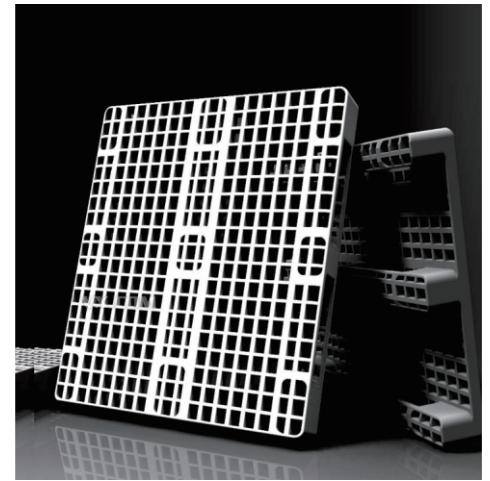

# CLAMPING UNIT

## 锁模单元

### 1 伺服液压系统

Servo hydraulic system

欧洲进口伺服马达与油泵的双重配合，使得在能耗和效率上从一开始就领先。

The European servo motor and pump makes Demark machine gain the advantage of energy consumption and production efficiency in the very beginning among competitive market.

### 2 动板线性导轨

Moving platen on the liner guider

动板运行于线性导轨之上，获得更小的摩擦力，更好的平行度和更快的产品周期。

Less friction, better parallelism and faster cycle time all benefit from the liner guider design.

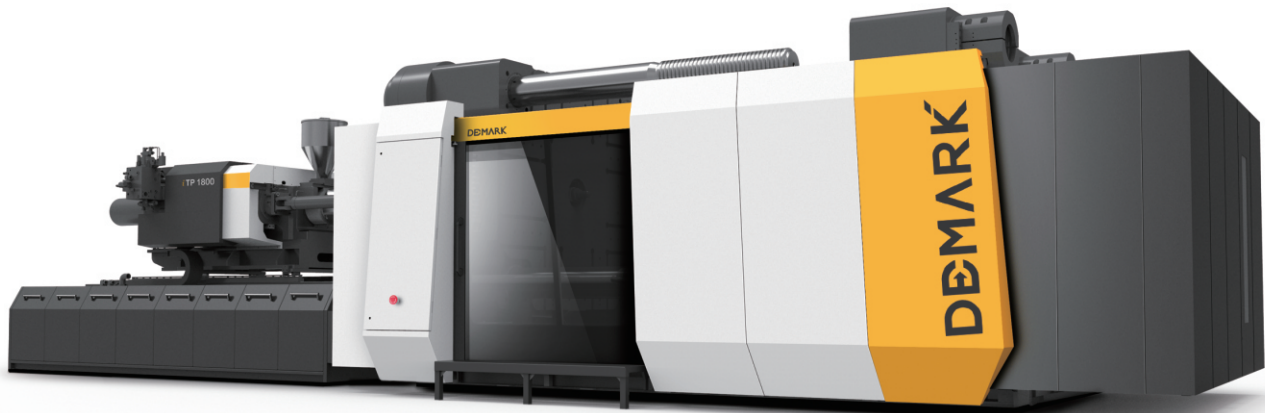

### 3 高刚性模板

Two rigid platen

通过优化两板的设计，使得两板刚性更好，变形量更小，结构紧凑，顶出方便。

By optimizing the two-platen design, make them have better rigid, less deformation, and the compact design make the ejecting smoother.

### 4 无接触拉杆设计

Non-contact tie bar design

无接触拉杆设计彻底改变了传统两板机导套和拉杆容易磨损的缺点，长久运行模板平行度好，并且无需润滑拉杆，避免了润滑油污染模具的可能性。

The non-contact tie bar design totally change the disadvantage of traditional two platen machine with the abrasion between the guide sleeve and tie bar. Moreover, the parallelism rarely changed after long time and make the mold area cleaner by preventing lubricant into the area.

# INJECTION UNIT

## 注射单元

### 1 高效塑化

High efficient plasticization

进口伺服电机溶胶，带来了节能和效率的双重提升。

Independent electric screw drive brings you both melting and energy efficiency.

### 2 设计紧凑

Compact design

平行双缸注塑使得注射更加稳定，人性化的设计使得更换螺杆易于操作。

Two parallel hydraulic injection pistons make the injection stable and reliable; humanized design makes it easier to change the screw.

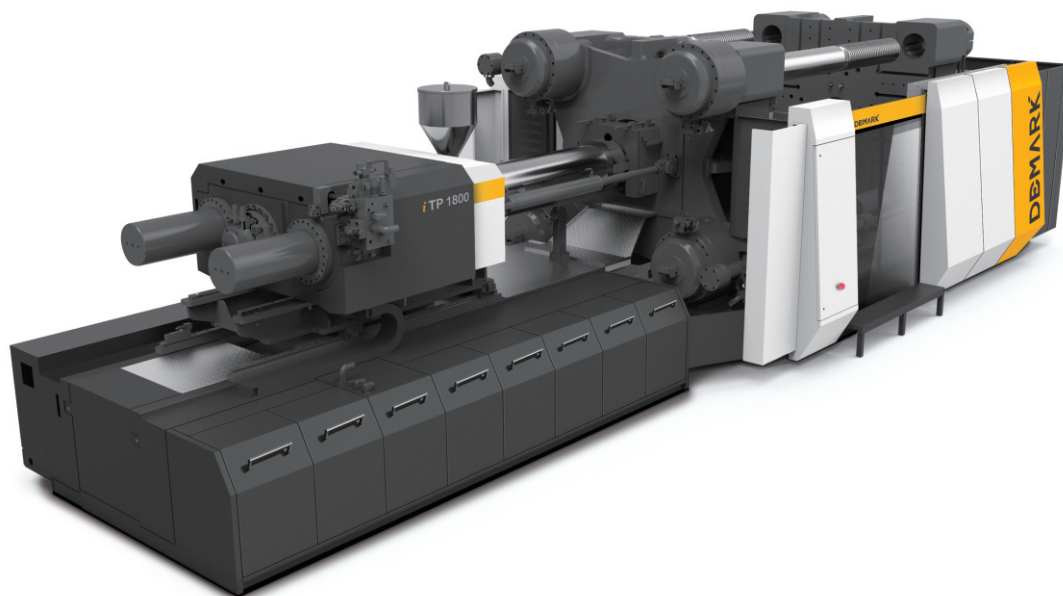

### 3 高效炮筒设计

High efficient barrel design

配备的纳米远红外加热圈以及高效螺杆，进一步增大了整个系统高效、节能的特点。

Equipped with Nano infrared heater and efficient screw, enhanced the system ability of efficiency and energy saving.

### 4 伺服驱动

Servo driving

整个系统的伺服驱动化，使得德玛克新型三板机开锁模和溶胶动作同时进行。

By using servo motor driving within the whole system, the mold open and clamping movement can be synchronized with plasticization.

# BENEFITS

## 完美的效益表现

整个德玛克iTP系列两板机的设计里面都是围绕着高效与节能，因此，我们的客户能从中获得以下优势体验：

The concept of high efficiency and lower energy consumption is always being together with the design of Demark two platen injection machine in order to let our customer gain the following advantage:

- 比同类注塑机节能高达25%以上。
- 最大化生产效益。
- 更快收回投资成本。
- Gain more than 25% energy saving.
- Maximize production efficiency.
- Return back of your investment within a short of time.



节能

LOW ENERGY CONSUMPTION



高效投资

LOW INVESTMENT

# MAIN TECHNICAL FEATURES

## 主要技术参数

锁模单元 CLAMPING		UNIT	iTP800		iTP1000		iTP1200		iTP1400		iTP1800	
锁模力	Clamping force	ton	800		1000		1200		1400		1800	
开模力(高压油缸开模)	Opening force	ton	80		100		120		140		180	
开模力(移模油缸开模)	Opening force	ton	23.8		26.7		33		36.3		43.6	
模板最大间距	Max. daylight	mm	2000		2300		2500		3000		3400	
开模行程	Clamping stroke	mm	1000-1600		1200-1850		1300-2000		1600-2400		1800-2700	
四柱间距	Distance btwn. Tie bars	mm	1100 x950		1200 x1000		1300x1100		1500x1300		1700x1500	
最小模具尺寸	Min mould dimension	mm	770x665		840x700		910x770		1050x910		1190x1050	
容模量	Mould thickness range	mm	400~1000		450~1100		500~1200		600~1400		700~1600	
顶针力	Ejector force	ton	19.9		19.9		23.7		27.9		40	
顶针行程	Ejector stroke	mm	300		300		350		350		400	
顶针数	No. of ejector pins	unit	21		21		29		29		25	
干周期(欧规6)	Dry cycle (Euromap 6)	S	4.1		4.4		4.8		5.2		5.8	
净重	Net weight	ton	23		30		37		47		67	

注射单元 INJECTION		UNIT	5300				7100				9600				15000				20000			
螺杆直径	Screw diameter	mm	80	90	100	90	100	110	100	110	120	120	130	140	130	140	150					
理论射胶容积	Theoretical shot volume	cm <sup>3</sup>	2262	2863	3534	3181	3927	4752	4320	5227	6220	7351	8628	10006	9291	10776	12370					
射胶量(PS)	Shot weight (PS)	g	2036	2577	3181	2863	3534	4277	3888	4704	5598	6616	7765	9005	8362	9698	11133					
螺杆长径比	Length/Diameter ratio	L/D	24.8	22.0	19.8	24.4	22.0	20.0	24.2	22.0	20.2	23.8	22.0	20.4	23.7	22.0	20.5					
射胶压力(高压低速)	Injection pressure(high pressure and low speed)	Mpa	236	187	151	222	180	149	222	183	154	212	181	156	212	183	160					
射胶压力(低压高速)	Injection pressure(low pressure and high speed)	Mpa	199	157	128	185	150	124	184	152	128	180	154	132	161	139	121					
射胶速率(高压低速)	Injection rate(high pressure and low speed)	cm <sup>3</sup> /sec	668	846	1044	779	962	1163	868	1050	1250	1197	1404	1629	1359	1576	1809					
射胶速率(低压高速)	Injection rate(low pressure and high speed)	cm <sup>3</sup> /sec	792	1002	1237	937	1156	1399	1047	1267	1508	1410	1655	1920	1793	2079	2387					
熔胶率(PS)	Plasticizing capacity (PS)	g/s	51	74	102	74	102	136	90	121	171	158	186	233	239	300	382					
射胶行程	Injection stroke	mm	450				500				550				650				700			
螺杆转速	Screw speed	rpm	123(150)				123(130)				109(130)				101(130)				130			
射台拉力	Injection unit force	ton	24.5				24.5				24.5				31.3				31.3			
射台行程	Carriage stroke	mm	650				700				750				850				1000			
主马达功率	Major motor	KW	136				144				160				216				240			
加热区	No. of heater zones	unit	6+1				6+1				6+1				6+1				6+1			
电热功率	Heater input power	KW	47				51				56				89				93			
注油量	Oil filling capacity	L	1000				1200				1300				1900				2000			
净重	Net weight	ton	10				12				14				17				23			

德玛克保留对产品进行修改的权利，规格如有变动，恕不另行通知。

Demark reserve the rights to make any product improvement or specification change without prior notice.



# MAIN TECHNICAL FEATURES

## 主要技术参数

锁模单元 CLAMPING		UNIT	iTP2300		iTP2800		iTP3300		iTP4000		iTP6600						
锁模力	Clamping force	ton	2300		2800		3300		4000		6600						
开模力(高压油缸开模)	Opening force	ton	230		280		330		400		660						
开模力(移模油缸开模)	Opening force	ton	51.5		69.3		84.4		119		166						
模板最大间距	Max. daylight	mm	3800		4000		4200		4600		5200						
开模行程	Clamping stroke	mm	2000-3000		2100-3100		2200-3200		2400-3600		2700-4000						
四柱间距	Distance btwn. Tie bars	mm	1900x1700		2000x1800		2200x2000		2300x2100		2500x2300						
最小模具尺寸	Min mould dimension	mm	1330x1190		1400x1260		1540x1400		1610x1470		1750x1610						
容模量	Mould thickness range	mm	800-1800		900~1900		1000~2000		1000~2200		1200~2500						
顶针力	Ejector force	ton	47.5		55.7		61.8		66		70						
顶针行程	Ejector stroke	mm	450		500		550		550		600						
顶针数	No. of ejector pins	unit	25		25		25		29		29						
干周期(欧规6)	Dry cycle (Euromap 6)	S	7.2		7.8		8.8		10		12.5						
净重	Net weight	ton	90		130		137		200		230						
注射单元 INJECTION		UNIT	30000		55000		68000		86000		110000						
螺杆直径	Screw diameter	mm	140	160	180	180	200	220	200	220	240	220	240	260	240	260	280
理论射胶容积	Theoretical shot volume	cm <sup>3</sup>	12315	16085	20358	25447	31416	38013	34558	41815	49763	45616	54287	63712	58811	69021	80048
射胶量(PS)	Shot weight (PS)	g	11084	14476	18322	22920	28724	34212	31102	37633	44787	41054	48858	57340	52930	62119	72043
螺杆长径比	Length/Diameter ratio	L/D	25.1	22	19.6	24.4	22.0	20.0	24.2	22	20.2	24.0	22.0	20.3	23.8	22.0	20.4
射胶压力(高压低速)	Injection pressure(high pressure and low speed)	Mpa	230	176	139	214	174	144	196	162	136	190	159	136	188	160	138
射胶压力(低压高速)	Injection pressure(low pressure and high speed)	Mpa	196	150	119	183	148	123	167	138	116	163	137	117	160	136	118
射胶速率(高压低速)	Injection rate(high pressure and low speed)	cm <sup>3</sup> /sec	1376	1797	2274	1796	2217	2683	2254	2728	3246	3103	3692	4333	3652	4286	4971
射胶速率(低压高速)	Injection rate(low pressure and high speed)	cm <sup>3</sup> /sec	1611	2104	2662	2101	2594	3139	2640	3195	3802	3609	4295	5040	4285	5029	5832
熔胶率(PS)	Plasticizing capacity (PS)	g/s	184	250	339	296	351	425	301	364	602	273	451	392	401	348	437
射胶行程	Injection stroke	mm	800		1000		1100		1200		1300						
螺杆转速	Screw speed	rpm	80		70		60		45		40						
射台拉力	Injection unit force	ton	31.3		37.9		37.9		41.2		41.2						
射台行程	Carriage stroke	mm	1000		1000		1150		1770		1770						
主马达功率	Major motor	KW	272		360		345		460		533						
加热区	No. of heater zones	unit	6+1		6+1		6+1		6+1		6+1						
电热功率	Heater input power	KW	123		172		202		228		268						
注油量	Oil filling capacity	L	2300		2700		3200		4200		5000						
净重	Net weight	ton	30		40		50		80		100						

德玛克保留对产品进行修改的权利，规格如有变动，恕不另行通知。

Demark reserve the rights to make any product improvement or specification change without prior notice.

## 德玛克控股集团

地址: 中国浙江省湖州市长兴国家级开发区发展大道2587号

电话: 0572-6559071

上海分公司电话: 021-60391126

邮箱: sales@demark-pet.com

.....

### DEMARK HOLDING GROUP

Add: No. 2587, Development Avenue, Changxing, Huzhou, Zhejiang Province, China

TEL: +86-572-6559071

SHANGHAI BRANCH TEL: +86-21-60391126

EMAIL: sales@demark-pet.com

**www.demark-pet.com**

ISO9001 & CE

©Copyright DEMARK CO., LTD. Information subject to alteration. 2017-11版

◇ 由于印刷的关系, 故正式机器的颜色与所示的图片有部分差异, 一切以机器实样为准。

